

Section D-D  
3232A

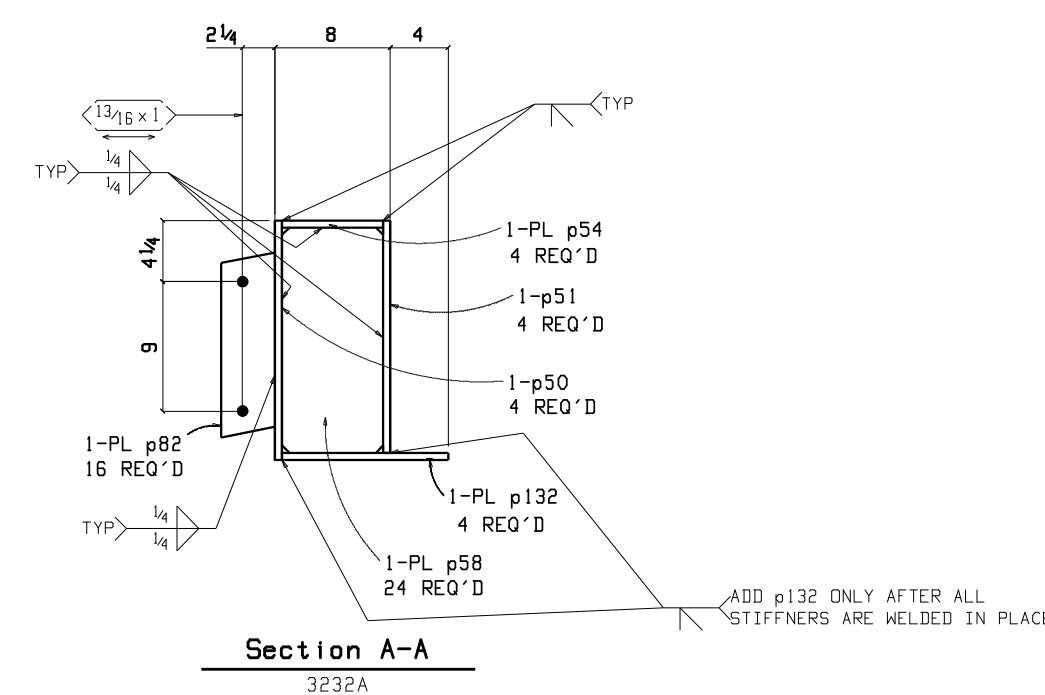

Section A-A  
3232A

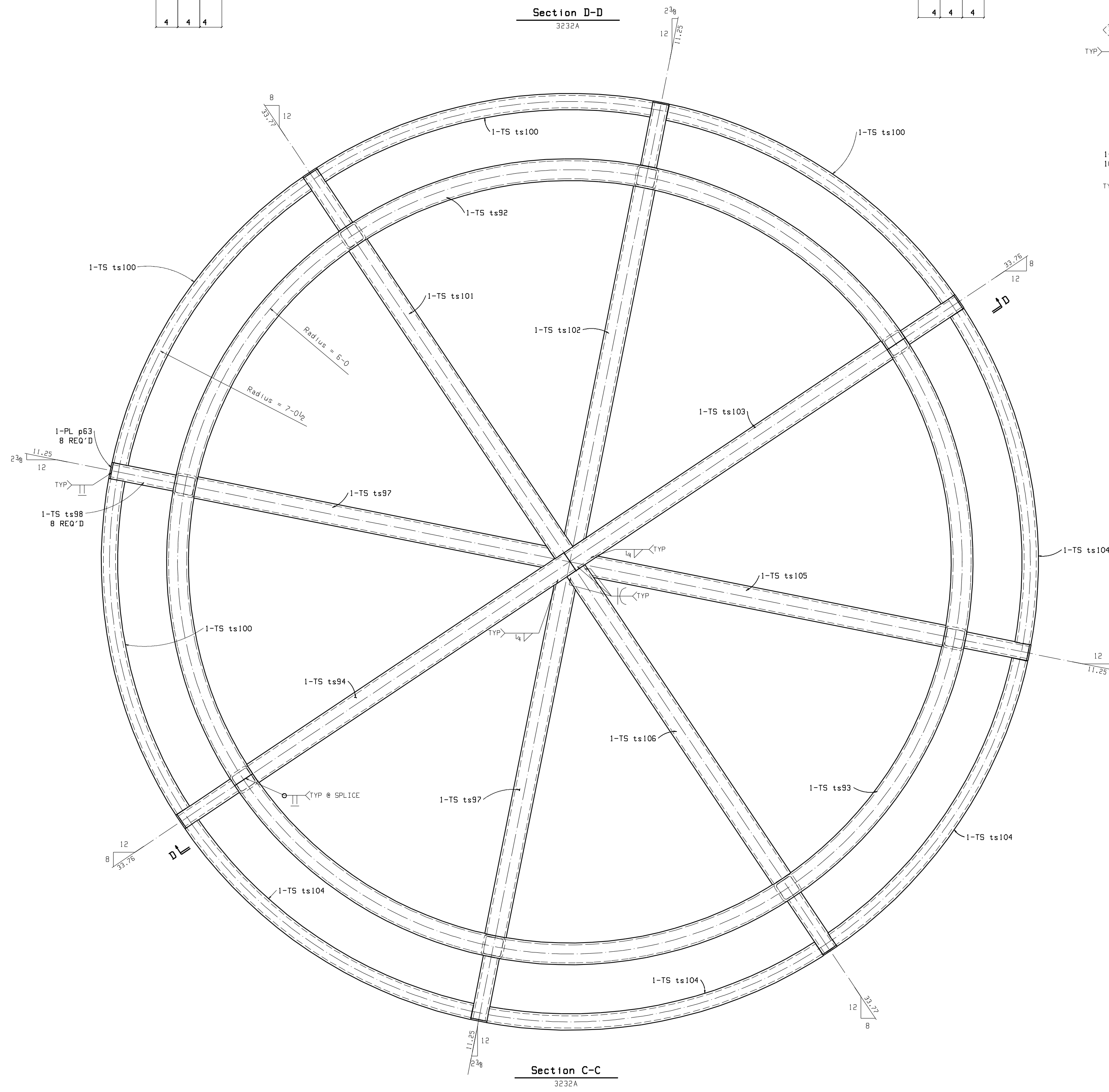

Section C-C  
3232A

AESS

ACTION TO BE TAKEN	CATEGORY 2
SPECIAL CARE IN PROCESSING AESS	X
WELDS GROUND SMOOTH	X
WELDS CONTOURED & BLENDED	X
WELD SHOWN THOUGH MINIMIZED	X
PIECE MARKS HIDDEN	X
ROLLED MEMBERS: MINIMIZE DISTORTION	X
BOLT HEAD ORIENTATION DICTATED	X
FIELD WELDING AIDS REMOVED	X
CLOSE WELD ACCESS HOLE AT FUL PEN WELDS	X
GRIND DOWN ALL MILL DESIGNATION MARKS ON STEEL	X

WORK WITH  
DWG # 3232

- ACCUMULATIVE DIMENSIONS ARE TAKEN FROM THE  $\odot$  LINE
- ALL GAS RE-ENTRANT CUTS WILL HAVE A RADIUS OF  $\frac{1}{2}$ " U.N.O.
- ALL CONN. MAT. A36 (U.N.), PIPE A53, TUBE A500 Gr.B
- TOLERANCES-AISC UNLESS NOTED
- DEBURRING OF HOLES IS REQUIRED IF BURR EXCEEDS  $\frac{1}{16}$ "
- $\otimes$  INDICATES SIDE OF PLATE SHOP IS TO PAINT A SPOT ON FOR ERECTION PURPOSES.
- NO PAINT WITHIN 3" OF OPEN HOLES
- SPLICE WELD, CONTINUOUS FLAT PLATE, BENT PLATE OR ANGLES WHERE NEEDED USING SEAL WELD PROCEDURE

**ORANGE COUNTY IRONWORKS LLC**  
36 MAYBROOK ROAD MONTGOMERY N.Y. 12549  
845-769-3000

PRINT RECORD			STRUCTURE CONEY ISLAND STEEPLCHASE				
QUANTITY	DATE	COPY	LOCATION	BROOKLYN, NEW YORK			
			CONTRACTOR HUNTER ROBERTS CONSTRUCTION GROUP				
			OWNER CITY OF NEW YORK PARKS & RECREATION				
Conns. A36 Unless Noted			ENG. OR ARCH'T ROCKWELL GROUP				
Holes 1 3/16 Unless Noted							
Surf. Prep SP3							
D.F.T.			REV	DATE	DESCRIPTION	PROJ NO.	SHEET NO.
Paint		STD. PRIMER	1	01-12-12	RELEASED FOR APPROVAL	11101	3233
Made	JPT	Date 01-11-12	2	03-25-12	RELEASED FOR FABRICATION		
Chk'd	KVD	Date 01-12-12	3				
			4				