

TEMPORARY CUPOLA ROOF SUPPORT PART PLAN

NOTES:
1. TOP OF STEEL ELEVATION = 38'-9 3/8"

ERECTOR NOTE:
BRACE WITH GUY WIRE PRIOR TO CUPOLA INSTALLATION

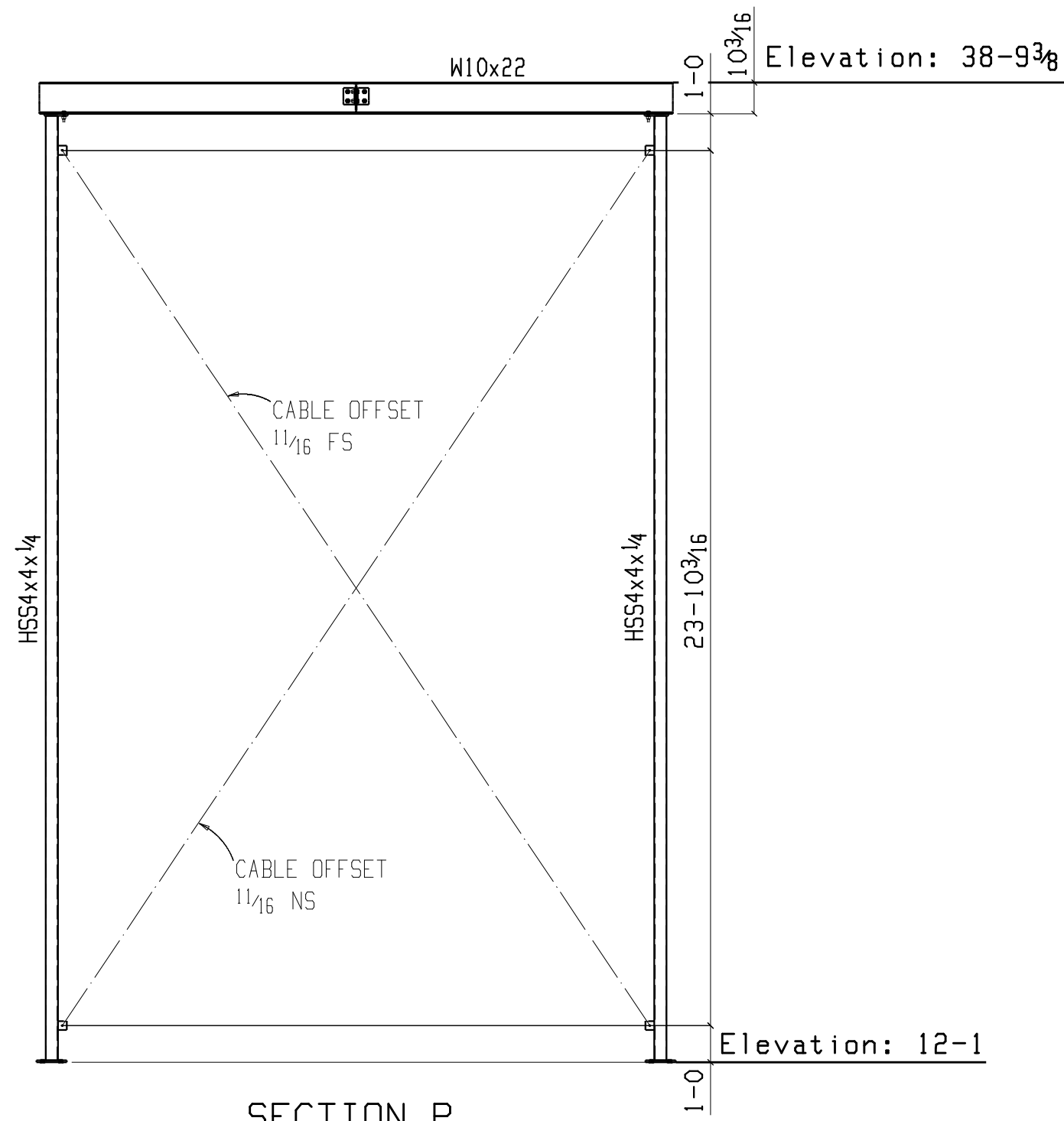

SECTION P

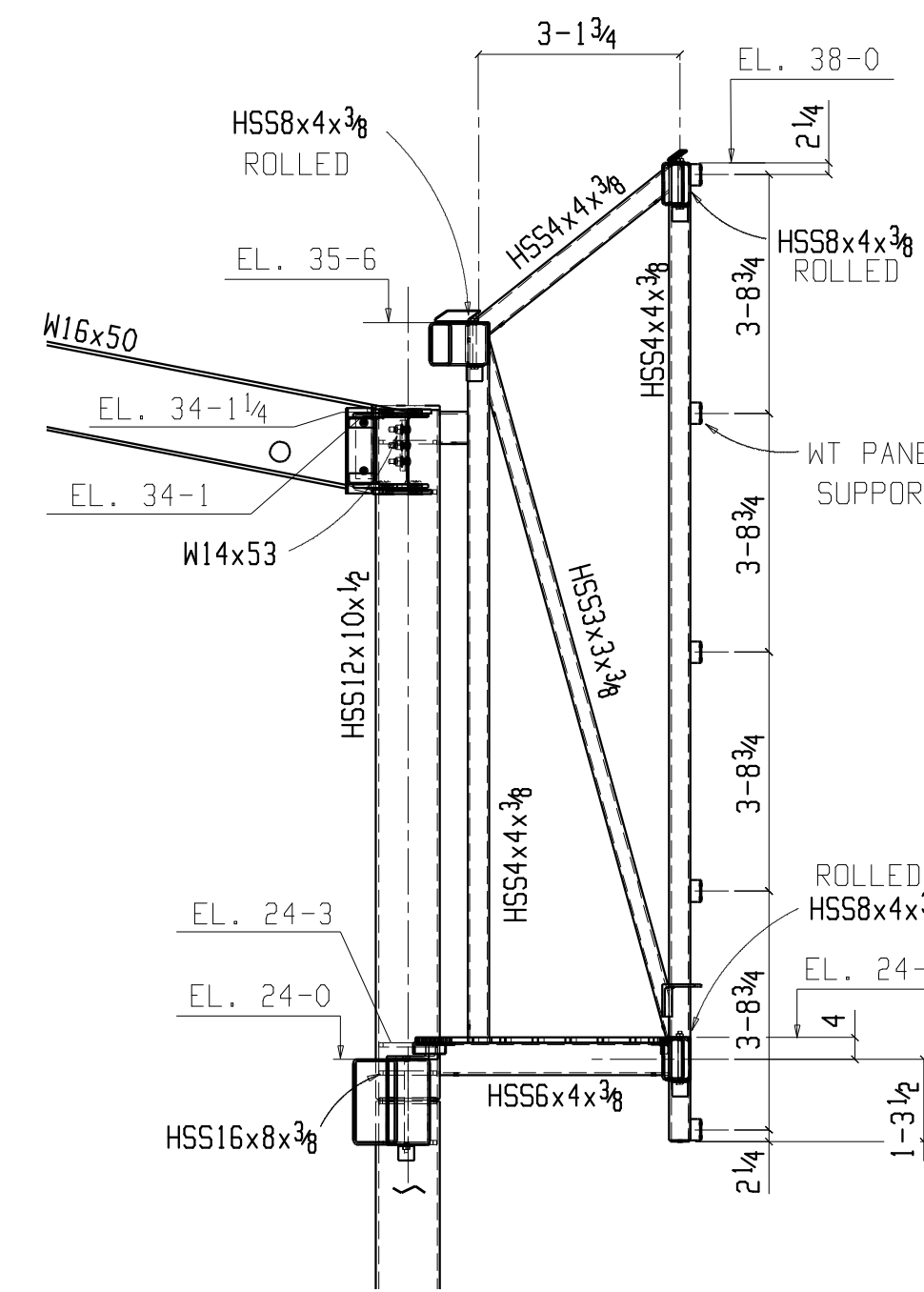

SECTION A

(REF: ORIGINAL SECT. A/3E2)

- LOCATION - PCMK
- B/1 - 3115A
 - C/1 - 3115A
 - D/1 - 3115A
 - E/1 - 3111A
 - F/1 - 3111A
 - G/1 - 3111A
 - H/1 - 3111A
 - I/1 - 3111A
 - J/1 - 3111A

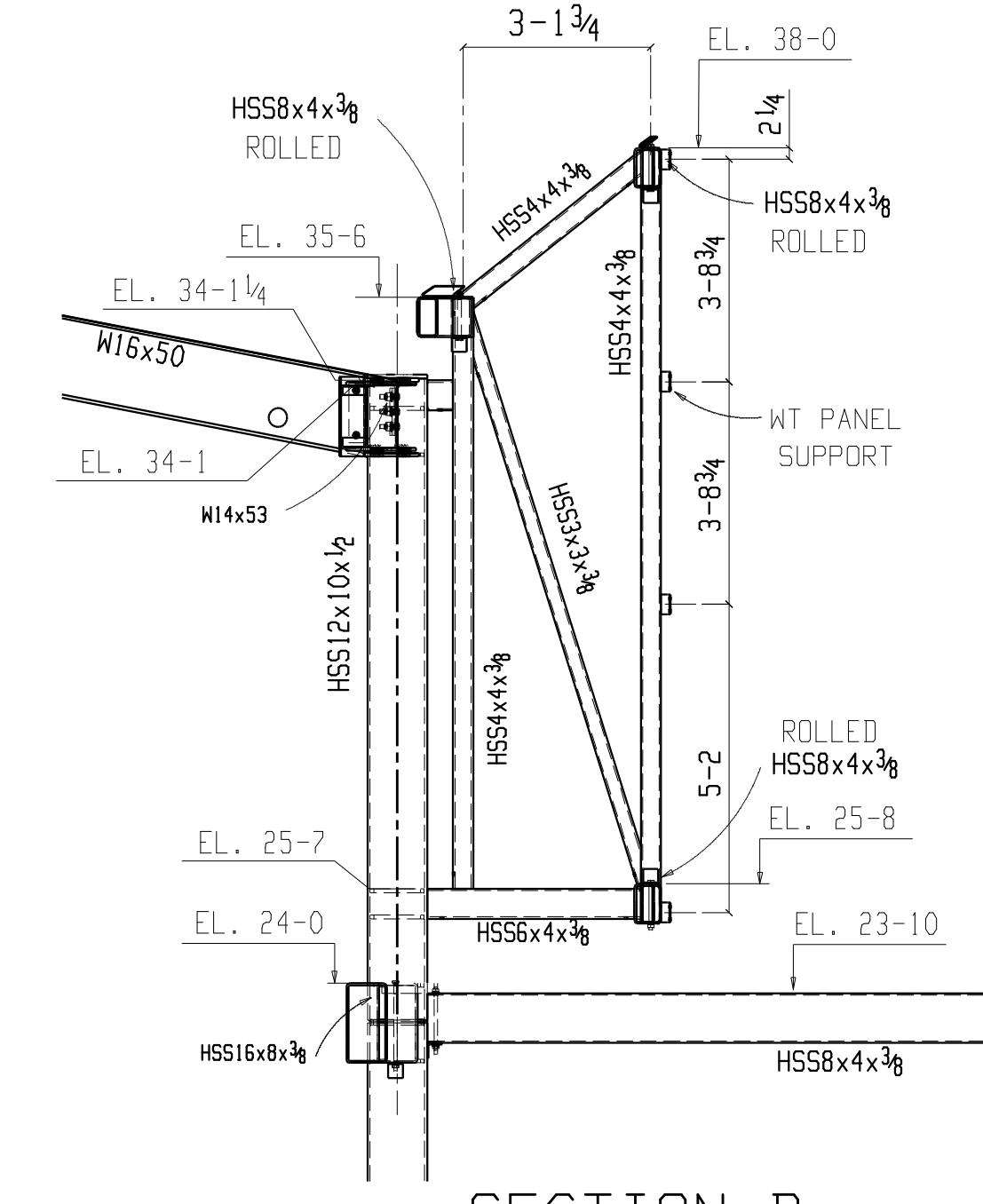

SECTION B

(REF: ORIGINAL SECT. B&C/3E2)

- LOCATION - PCMK
- K/1 - 3108A
 - L/1 - 3107A
 - M/1 - 3106A
 - O/1 - 3118A
 - P/1 - 3117A
 - A/1 - 3116A

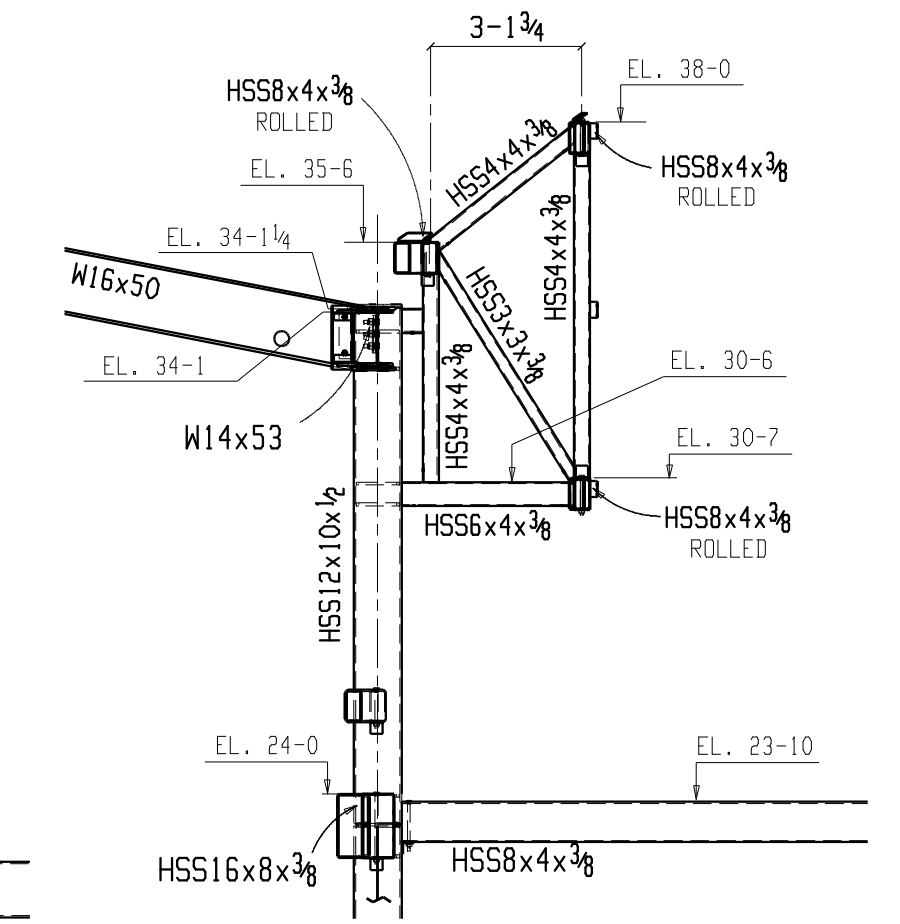

SECTION D

(REF: ORIGINAL SECT. B&C/3E2)

LOCATION - PCMK
N/1 - 3105A

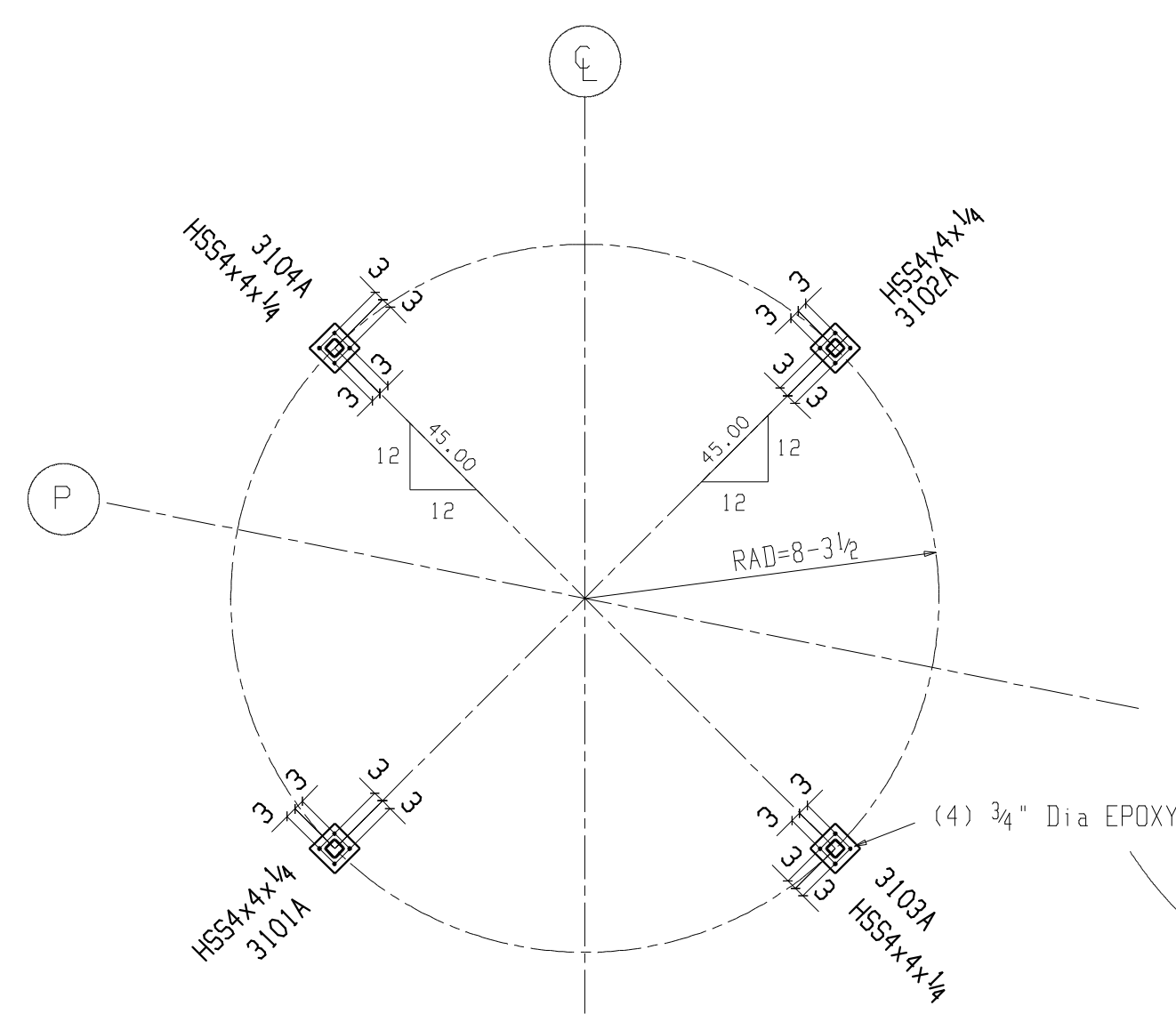

TEMPORARY CUPOLA ROOF SUPPORT AB PART PLAN

NOTES:
1. BTM OF BPLT ELEVATION = 12'-1"

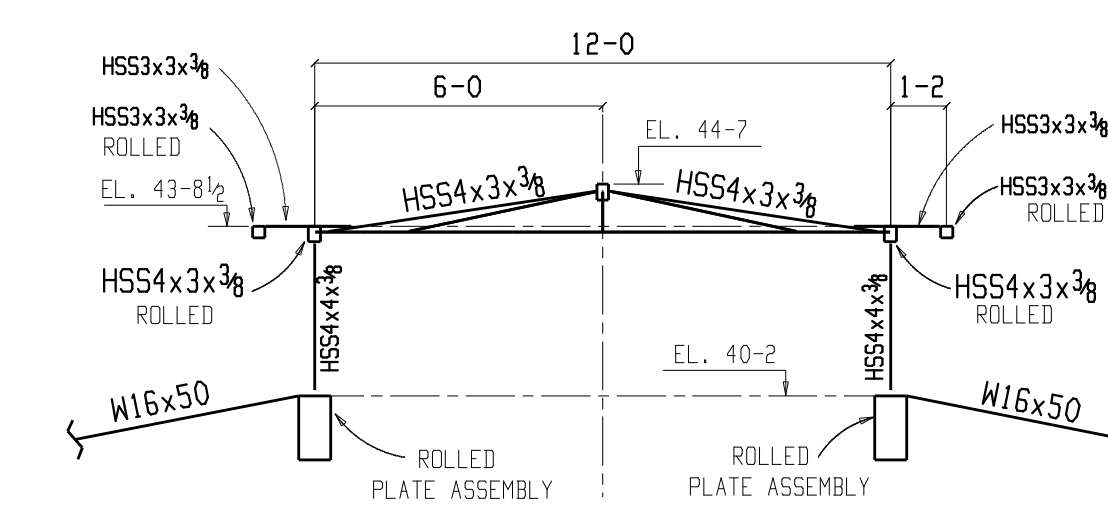
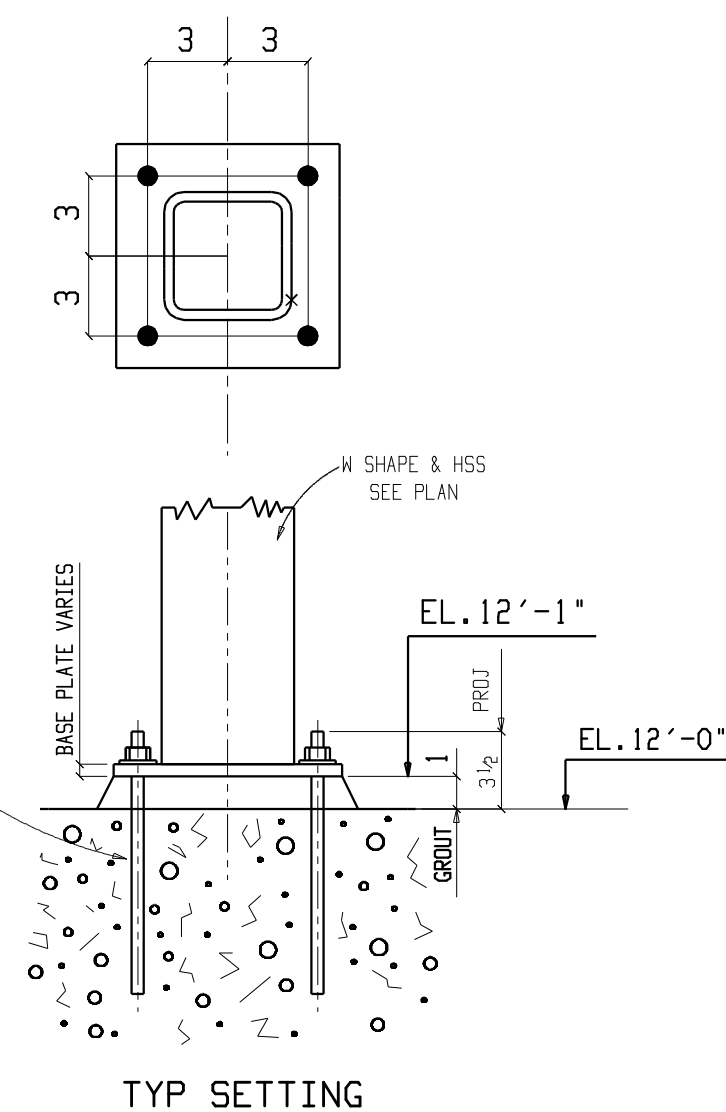

SECTION F

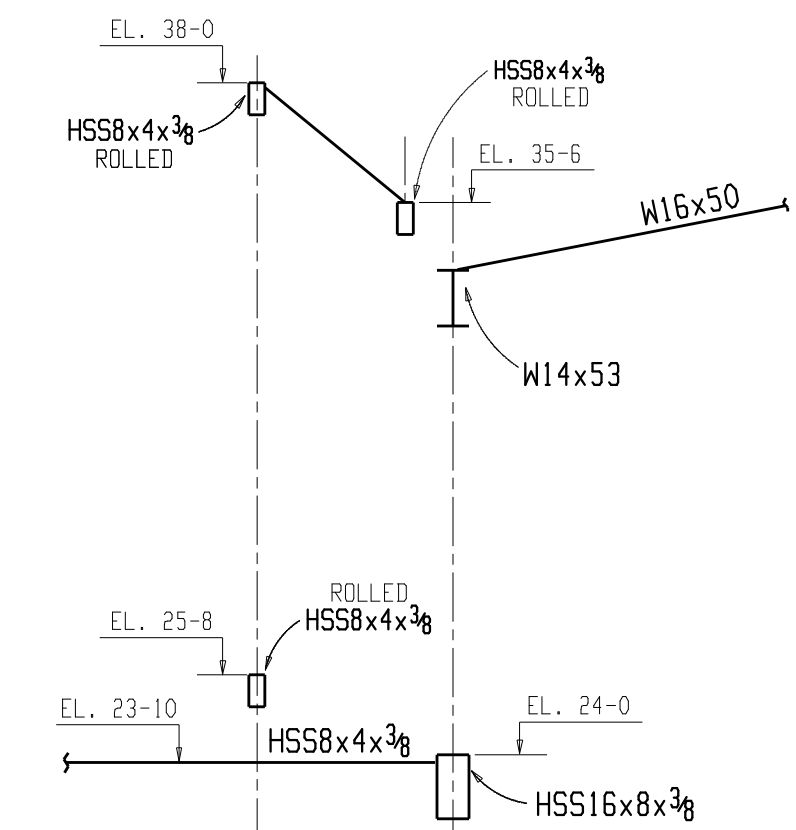

SECTION E

GENERAL NOTES:
1. ANY EXPOSED STEEL MUST HAVE TEMPORARY ERECTION HOLES AND ANGLES REMOVED AND THE STEEL RESTORED TO ITS INTENDED CONDITION.
2. DRAIN HOLES AND VENT HOLES MUST BE FILLED AFTER WELDING IS FINISHED.

ORANGE COUNTY IRONWORKS LLC
36 MAYBROOK ROAD MONTGOMERY N.Y. 12549
845-769-3000

PRINT RECORD			STRUCTURE CONEY ISLAND STEEPLCHASE				
QUANTITY	DATE	COPY	LOCATION BROOKLYN, NEW YORK				
			CONTRACTOR HUNTER ROBERTS CONSTRUCTION GROUP				
			OWNER CITY OF NEW YORK PARKS & RECREATION				
Conns	A36	Unless Noted	ENG. OR ARCH'T ROCKWELL GROUP				
Holes	13/16	Unless Noted	REV	DATE	DESCRIPTION	PROJ NO.	SHEET NO.
Surf. Prep			1	01-12-12	RELEASED FOR APPROVAL	11101	3E2
Paint			2	03-25-12	RELEASED FOR FIELD USE		
Made	JPT	Date 12-15-11	3				
Chk'd	KVD	Date 01-12-12	4				